

User manual

Kabola Compact



Kabola Heating Systems BV
Placotiweg 1E
4131 NL Vianen (Utr.)
Nederland



Preface

This user-manual is written to enable the safe operation of the Compact-series central heating boilers. The user must read this manual before installation of the boiler and must follow the instructions within this manual.

Therefore, this manual must be kept with the boiler.

In chapter 2, the safety instructions are detailed, which have to be complied with, when installing and using the boiler. In other chapters you will find safety instructions, that can be identified in the following way.

Hint: This gives the user suggestions and advises to facilitate the execution of certain tasks.

Attention: Additional information is supplied to the user, and possible problems are indicated.

Warning: Watch out for possible (life-threatening) injuries.

For any remarks, wishes or omissions you can contact Kabola Heating Systems. We also welcome any remarks to improve this manual. We wish you a lot of pleasure from your purchase.

Kabola Heating Systems
Placotiweg 1E
NL 4131 NL Vianen
The Netherlands
Phone +31 (0)347-320030
Fax +31 (0)347-355688
Web: www.kabola.nl
E-mail info@kabola.nl

Vianen, July 2014

© 2014 Kabola Heating Systems
Copying of (parts of) this manual, is only allowed with written consent of Kabola Heating Systems.

Table of contents

Preface	2
Table of contents	3
1 Introduction	4
1.1 General	4
1.2 Range of application	4
1.3 Product description	4
1.4 Technical specifications	4
2 Safety	5
2.1 General safety	5
2.2 Safety instructions	5
3 Transport and storage	6
3.1 Transport	6
3.2 Storage	6
4 Installing and preparing for first use	7
4.1 Installation	7
4.1.1 Fitting the boiler	7
4.1.2 Connection to the central heating system	7
4.1.3 Flue gas outlet	8
4.1.5 Electrical connection	10
4.1.6 Filling the central heating system	11
4.1.7 Mounting the oil burner	12
4.1.8 Mounting the oil filter and oil burner.	12
4.2 Starting your system	13
5 Operating the boiler	13
5.1 Explanation of the dashboard	14
6 Cleaning and maintenance	15
6.1 Points for attention	15
6.2 Cleaning and maintenance	15
7 End of life of the boiler	15
Appendix A Technical specifications	16
Appendix B Electrical diagram 230 V	17
Appendix C Troubleshooting	18
Appendix D Boiler parts	19

1 Introduction

1.1 General

Congratulations with your purchase of this Kabola boiler. This user-manual covers the Compact-series. The Compact-boilers cover a wide range of boilers with a broad range of applications. By purchasing this boiler, you have acquired a product, which is of high quality through the application of the latest European standards and directives.

1.2 Range of application

The Compact-boilers are designed to generate heat for the heating of water for a central heating system.

The dimensions of the rooms to be heated, have to be taken into consideration. These boilers are not designed for direct heating of the rooms in which they are installed.

1.3 Product description

The boilers of the Compact-series heats the boiler water by means of a pressure jet burner which is installed at the front of the boiler. The boilers are available in 230 VAC. For fuel, diesel oil has to be used.

1.4 Technical specifications

The most important technical specifications are listed on the plate at the back of the boiler. More technical details are listed in Appendix A.

2 Safety

In this chapter we emphasize the safety-related points for operating the boiler.

2.1 General safety

Warning: Although Kabola Heating Systems designs and produces its products according to the current safety standards, it is possible that dangers may present themselves, which could lead to injuries or damage to the boiler, if the safety instructions in this manual are not complied with.

The user must:

- Have read and understood the chapter "safety";
- Avoid any actions which may lead to dangers to his health or others;
- Avoid any actions which may lead to damage to the boiler;
- Ensure that the boiler is only used when the boiler is in sound technical condition;
- Ensure that the safety regulations are observed whilst operating the boiler.

Attention: No alterations to the boilers may be done, without the explicit written consent of Kabola Heating Systems!

2.2 Safety instructions

In this chapter we emphasize the safety-related points for operating the boiler.

MEASURES FOR A SAFE INSTALLATION

- Don't store any flammable and/or gaseous products in the room where the boiler is installed to avoid explosions and fires.
- Install the boiler in a non-humid environment on a firm horizontal base.
- Ensure that there is sufficient ventilation in the room where the boiler is installed (See also § 4.1.1).
- Make sure, before you start connecting the boiler, that the system is disconnected from the power supply.
- Only use multi-stranded wire for electrical connections.

MEASURES FOR A SAFE OPERATION

- Never change the settings of the burner.
- Don't use any aggressive solvents which may affect the boiler (like petrol or turpentine).
- Insulate the chimney, when it can be touched by body parts.
- Make sure that the boiler and burner are checked annually by a skilled expert.
- Make sure that before you start any work on the boiler that the system is disconnected from the power supply.
- Make sure that any surplus oil is collected in case of oil spillage.
- We advise you to have any maintenance or repairs carried out by skilled experts.

3 Transport and storage

3.1 Transport

Take following precautions before transporting the boiler:

- Drain the water from the boiler;
- Uncouple the fuel system;
- Remove the burner (see § 4.1.5, replacing the burner).

While transporting the boiler take following precautions:

- Don't damage the boiler, use a blanket to cover the boiler;
- Transport the boiler standing up.

3.2 Storage

Take the following precautions when the boiler is stored for a longer period of time:

- Store the boiler and accompanying parts in a dry place;
- Dismount the burner (see § 4.1.7.)
- Store the boiler standing up;
- Store the boiler on a firm horizontal base.

4 Installing and preparing for first use

In this chapter you will find directions and hints for a correct placement and fitting of the boiler and accompanying parts.

Warning: Do not store any flammable or gaseous substances in the room where the boiler installed. This is to ensure that no explosions or fires can occur.

4.1 Installation

4.1.1 Fitting the boiler

- Install the boiler in a dry place.
- Install the boiler on a firm horizontal base.
- Make sure there is sufficient supply of fresh air in the room where the boiler is installed (see hint below).
- To avoid movement secure the base of the boiler by using the holes with M5 thread in the feet from the boiler.
- Keep a minimum distance of 250 mm behind the boiler for the flue-gas outlet (see figure 1).
- Use an earthed plug socket for connecting the 230 Volt AC versions to the power supply.

Hint: As a rule of thumb for the ventilation openings, take 2,5 times the diameter of the flue gas outlet.

4.1.2 Connection to the central heating system

PIPING

Take note of the following points, when installing the piping:

- Install the piping in such a way, that the boiler (cover and dashboard) remains accessible;
- Provide enough bleeding points in places where air may collect, especially near the boiler.

Attention: Install a bleeding point near the boiler, especially when the piping does not go up.

Connect the piping to the boiler as follows (see figure 2):

1. Install the feed from the CH at the upper connection
2. Install the return of the CH at the waterpump.
(the waterpump is mounted on the lower connection)

Hint: Install a shunt with pressure equalizer, when thermostatic radiator valves are applied.

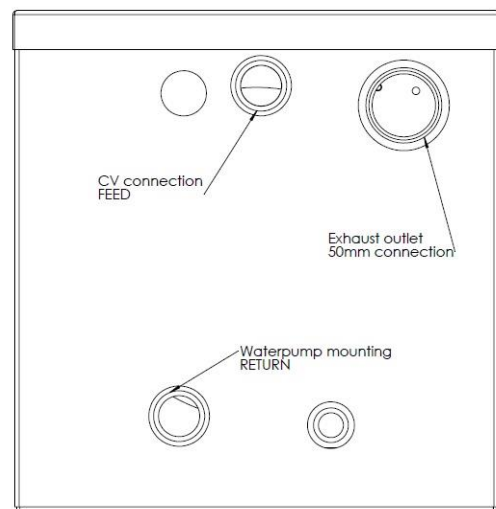

4.1.3 Flue gas outlet

GENERAL

The flue gas outlet is an essential part of your heating installation. An incorrect flue gas outlet reduces the lifespan of your boiler considerably and has a negative impact on the efficiency. Remember when installing the flue, that even the best boiler won't work properly unless the flue is properly installed.

Warning: Because the flue gas temperature lies between 180-240°C, it is advisable to insulate the flue with heat-resistant material on those parts where contact with human body parts is possible.

For a correct flue gas outlet the following point need to be observed:

- Use the proper diameter, use a diameter equal to the diameter of the flue gas outlet on the boiler (see also technical specification).

Hint: When using an existing chimney of a larger diameter than the diameter on the boiler, you can install flexible piping of the correct diameter inside the existing chimney.

Warning It is necessary that condense water always can flow back to the drain or the boiler, avoid water bags!!

The flue can be installed in several different ways. You must carefully consider under which circumstances the boiler will be used. For sea going boats and sail boats we advise the installation of a vertical flue where the heel angles of the boat may be larger. The following installation examples are most common.

HORIZONTAL FLUE GAS OUTLET

It is possible to fit a horizontal flue gas outlet to the boiler. The following points need to be observed:

- Make sure that the outlet is positioned at a sufficient height above the waterline. If this is not possible use a swan neck bend in the pipe as in figure 3.
- Use the correct hull fittings for installing the flue through a hull side
- The maximum allowed length is 5 meters.
- Don't use more than 3 elbows of 90°.
- Every elbow of 90° is equivalent to 1 meter straight pipe

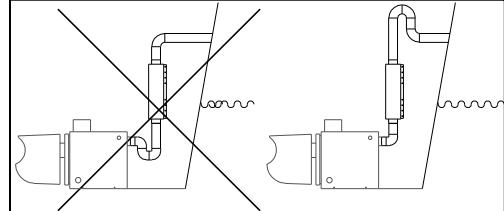

Figure 3

VERTICAL FLUE GAS OUTLET

This way of installation is preferable for seagoing boats and sailing boats, because these boats encounter large angles of heel through waves and under sail. For this kind of flue gas outlet, the following points are important:

- Install a proper storm cowl on top of the chimney (this must stop rain from entering) (figure 4).
- Install deck fittings for installing the flue through a deck.
- Install a water trap, to drain possible water caused by condensation
- Keep the chimney as vertical as possible.
- Don't use more than 3 elbows 90°.
- The maximum allowed length is 7 meters.
- Every elbow of 90° counts as 1 meter.
- Use outside double walled chimney pipe

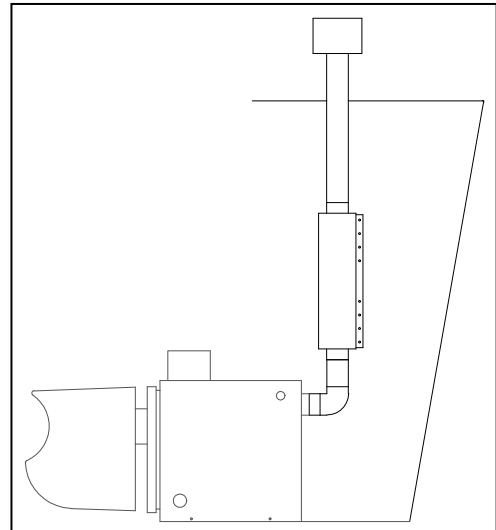

Figure 4

Hint: To reduce the noise from flames, it is wise to install a silencer in the flue.

Your Kabola supplier can provide you with all components which may be required for installation such as:

- Cowls;
- Flexible piping;
- Single and double walled chimney pipes;
- Hull and deck fittings;
- Silencers;
- Water traps;
- Insulation.

4.1.5 Electrical connection

Warning:

Disconnect the power supply from the boiler before you start the installation. **The quality of 230 VAC power supply to the boiler should be as good as the power supply from a land line.**



Figure 5

The power supply cable can be founded at the back (figure 5)

Connecting the room thermostat (Figure 6)



Figure 6



For connecting the room thermostat you must use a wire with 2 cores 0.75 mm² isolated hose. The room thermostat you need to connect at the following way:

- Remove the front of the dashboard with the two allen bolts on the side of the dashboard.
- Look for the white terminal block (figure 6) and remove the yellow loop-wire using a small flat blade screwdriver.
- Connect the wires from the room thermostat.

4.1.6 Filling the central heating system

The pressure in the system should:

- Never be lower than 0,5 bar cold;
- Never be higher than 2,5 bar hot.

Follow the procedure below for filling the CH-system (see figure 7):

1. Switch off the boiler (figure 11);
2. Remove nob 4
3. Screw the adaptor 3 at the thread,
4. Connect the filling tube at 3 and open 5 by turning it;
5. Fill the system slowly with water, until the pressure indicator indicates a pressure of 2 bar;
6. Close the valve (5);
7. Bleed the CH-system;
8. If necessary, fill with water again up to 2 bar of pressure;
9. Switch on the boiler and put the pump in its top (automatic bleed) position for 5 minutes (figure 8a);
10. Put the pumpswitch at a 3 o'clock position (between 3 and 6) (figure 8b);
11. Check the water pressure, if it is too low, repeat steps 5 through 10;
12. Remove the hose and adaptor. Fit the nob 4.

Hint: The CH-system can be filled with cooling fluid, suited for CH-systems (pH-value 8.5)

Bleeding the circulation pump

Reference in the pump manual for additional information

Attention: When locking pump couplings are supplied with the boiler, the adjusting grooves must point towards the pump.



Figure 8b

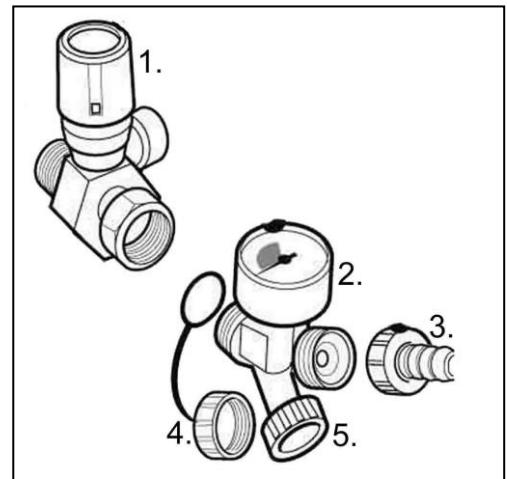

Figure 7

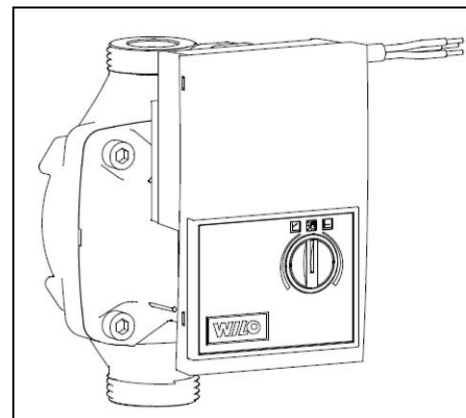

Figure 8a

4.1.7 Mounting the oil burner

Follow the instruction below for mounting the oil burner:

- Passionate the insulation (2) and the burner clamp (3) that they are in one line with the mounting holes in the door.
- Assemble the burner clamp with the 4 M8 bolts. The arrow at the burner clamp must point to the top.

Hint: Smear some sealant in the crack in the flange to seal

- Slide the burner trough the burner clamp and push it as far as possible.
- Fasten the screw from the burner clamp what is clamping the burner.

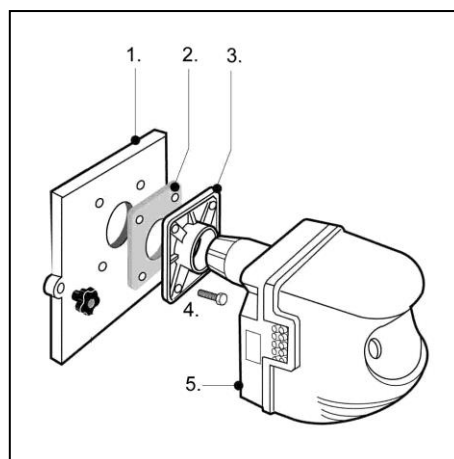

Figure 9

Attention: Take care that the flame tube is not damaged during installation. Repairs to the flame tube are very expensive and don't fall under warranty.

4.1.8 Mounting the oil filter and oil burner.

To connect the filter to the burner follow the procedure below (see also figure 9):

- Remove the burner cover from the oil burner (1);
- Connect the oil pump (2) to the oil filter (3), using the included fuel hoses. Make sure that the flow directions on the pump comply with those on the filter;
- Connect the fuel line from the tank to the filter (5A). The fuel line must have an outer diameter of 8 mm and must be made from copper or steel. The fuel line has to be connected directly to the oil tank. Correct functioning of the burner can not be guaranteed when a fuel manifold or T connection is installed;
- Connect the plug (4) from the boiler to the burner.

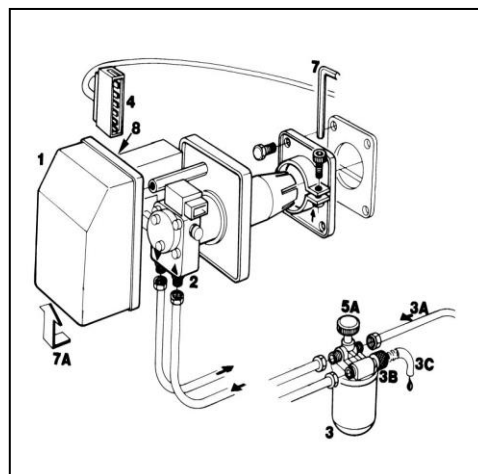

Figure 10

Hint: When the oil tank is situated below the boiler or when the oil supply line comes from below the boiler, it is advisable to use a self bleeding oil filter. The article number 4-D133. This prevents unnecessary malfunctioning of the burner. In the manual of the burner you will find an overview with the allowed dimensions of the oil supply line.



4-D131 Oilfilter (standaard)



4-D133 Oilfilter (optional)

4.2 Starting your system

When everything is connected follow the procedure below:

1. Connect the boiler to the power supply. The 230 VAC will need to be connected for the 230 VAC Switch the boiler on with the on/off switch on the dashboard. The lamp in the switch will indicate that the system is active.
2. Set the required boiler temperature between 55 and 90°C using the boiler thermostat.
3. Set the room thermostat so that it is switched on (see manual of the room thermostat)
4. Starting of the oil burner (see figure 10):
 - 4.1. Open the valve in fuel line (5);
 - 4.2. Install the bleed hose (3C) on the bleed opening of the oil filter;
 - 4.3. Open the valve on the oil filter (5A);
 - 4.4. Start the oil burner;
 - 4.5. The burner switches on, this will take approximately 1,5 minutes because of the oil pre-heating element;
 - 4.6. Open the bleed valve on the oil filter (3B);
 - 4.7. Check if oil is coming out of the hose(3C);
 - 4.8. Check all oil connections for leaks;
 - 4.8.1.If the burner does not start, the control light will light;
 - 4.8.2.Close the bleed valve (3B) on the oil filter;
 - 4.8.3.Wait approximately 3 minutes;
 - 4.8.4.Reset the burner by pushing button and return to 5.4 (repeat if necessary).
 - 4.9. Close the bleed valve(3B) when only oil and no bubbles come out of the hose;

Attention:

The oil burner is tested by the manufacturer, not adjusted. The adjustment of the burner has to be done by an experienced installer, because this requires expert knowledge. To be eligible for warranty, the boiler has to be adjusted by an approved installer. Contact your Kabola supplier to make an appointment.

Never adjust the burner using your own initiative.

5 Operating the boiler

When the boiler has been started and adjusted according to 4.2, operation for the boiler is very simple.

1. By pushing nob (D) from figure 11 you can set the boiler temperature.

The required temperature is set with the room thermostat, which controls the boiler. The calorifier thermostat controls the 3-way valve on the boiler. The operation of the room thermostat is explained in the manual of the room thermostat.

If problems arise with the operation of the boiler, you will find a list of possible problems and solutions in Appendix C.

5.1 Explanation of the dashboard

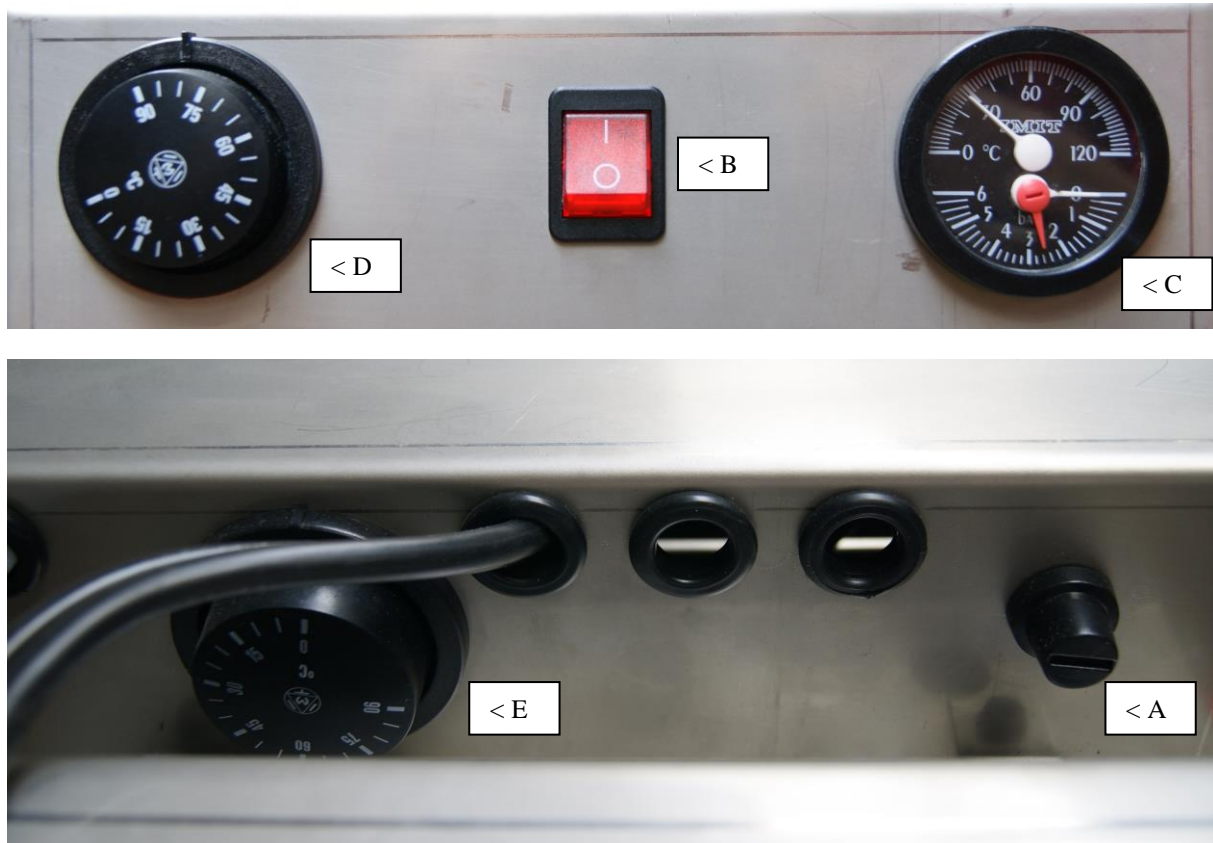

Figure 11

Explanation from the number in the figure 11:

- A. Reset nob maximal thermostaat,
- B. On/ off switch,
- C. Display for boiler temperature and pressure,
- D. Adjust nob for boiler temperature,
- E. Optional: Pump timer adjuster (not as standard).

6 Cleaning and maintenance

6.1 Points for attention

Spare parts must be ordered through your Kabola supplier. For warranty purposes only original spare parts must be used. When ordering spare parts, state the type of boiler and its serial number. Your Kabola supplier will then be able to supply the correct parts. In Appendix B, the main spare parts are listed.

6.2 Cleaning and maintenance

Warning: Maintenance and repairs should only take place when the boiler is switched off, this is because the boiler may start unexpectedly. Take the plug from the wall socket for the 230 VAC versions.

Warning: Maintenance and repairs may only be performed by personnel, who have read and understood the information in this manual, preferably an expert installer or a service engineer from Kabola Heating Systems.

Every year

1. Clean the boiler
 - 1.1. Remove the burner (see § 4.1.5);
 - 1.2. Remove the burner from the boiler;
 - 1.3. Open the door of the boiler,
 - 1.4. Remove the insulation.
 - 1.5. Clean the inside of the boiler, using a stiff brush;

Attention: Don't use any aggressive solvents like thinner or gasoline.

- 1.6. Clean the boiler with a vacuum cleaner;
 - 1.7. Replace the door, if necessary use a new isolation;
 - 1.8. Replace the burner;
2. Clean the chimney;
3. Change the oil filter element;
4. Clean the burner (see manual of the burner)

Attention: The old oil filter element has to be processed as chemical waste.

7 End of life of the boiler

When the boiler is scrapped, take note of the points listed below:

- Process the oil filter and the oil hose as chemical waste;
- Separate the metal from the plastic parts and dispose off them separately.
- Process any excess oil in an environmentally friendly way.
- Transport the boiler according to the instructions in chapter 3
- Recycle this manual.

Appendix A Technical specifications

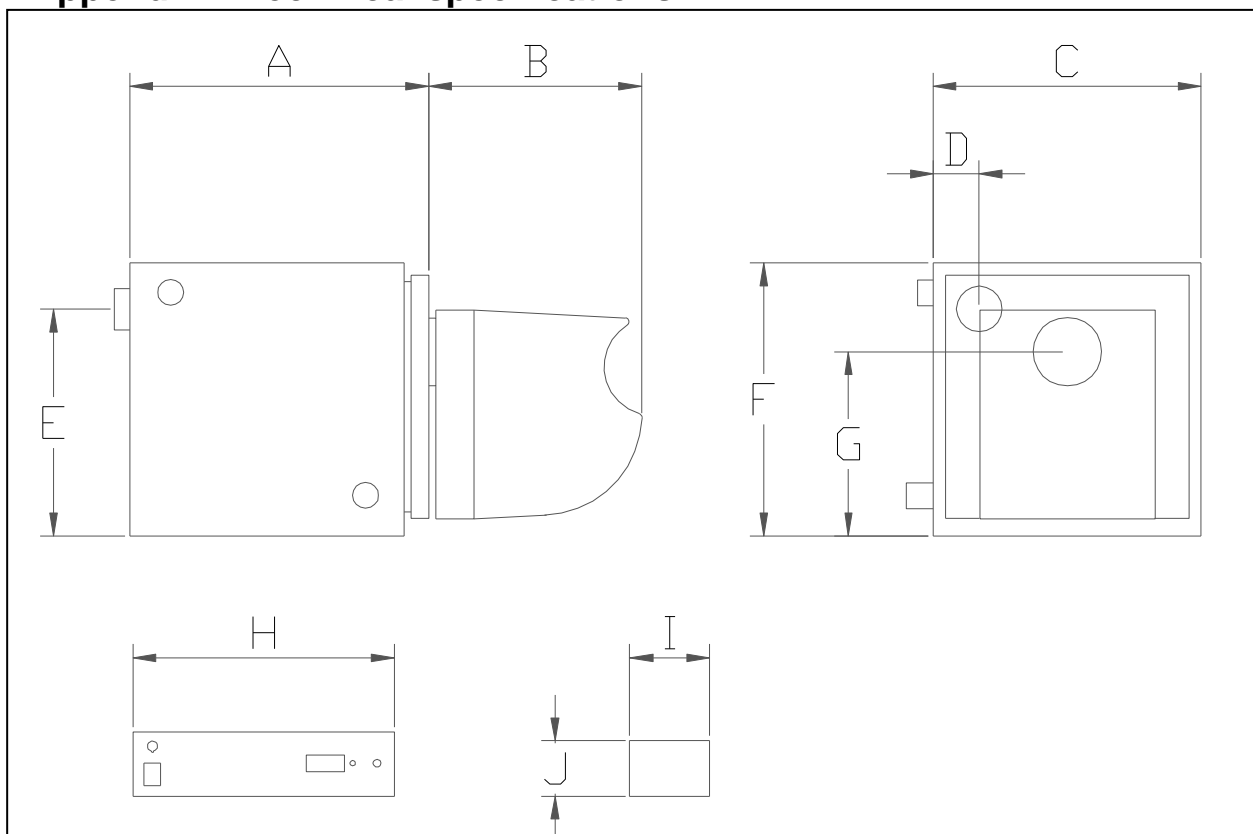

Boiler dimensions

Letter	Compact 7		
A	305 mm		
B	145 mm		
C	318 mm		
D	50 mm		
E	272 mm		
F	334 mm		
G	178.5 mm		
H	265 mm		
I	77.5 mm		
J	73 mm		

Technical specifications		Compact 7		
Flue gas Ø	mm	50		
C.H. connection	mm	22		
Max. capacity	kW	7		
Service pressure	Bar	2		
Working pressure	Bar	3		
Weight	Kg	47		
Exhaust gas temp. Max.	°C	195		
Efficiency	%	90		
Max. length horizontal max.	mtr.	5		
Power consumption 24V	A	6.9		
Power consumption 230V				
Power consumption 230V starting load	W	295		
Operating load 230V	W	255		
Fuel		Diesel		

Appendix B Electrical diagram 230 V

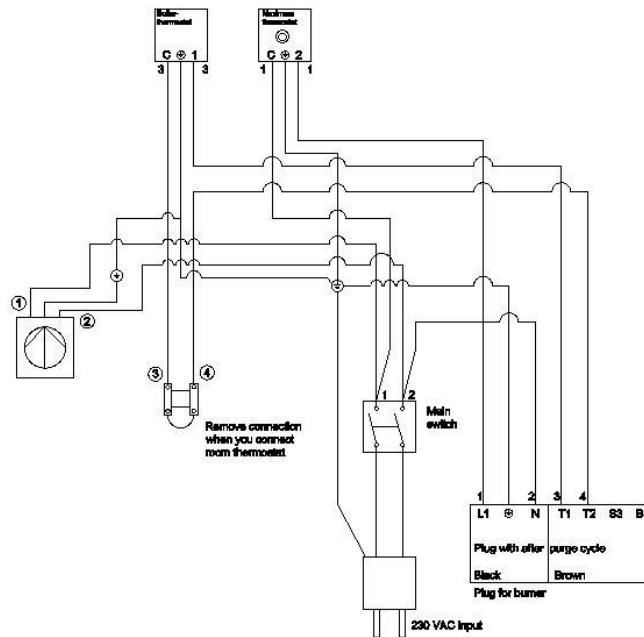

Dimensions wiring
 Power supply 1-1,5 mm²
 thermostat 1-1,5 mm²

Electrical diagram Compact 7

The wiring scheme below is for boilers fitted with the optional pump timer

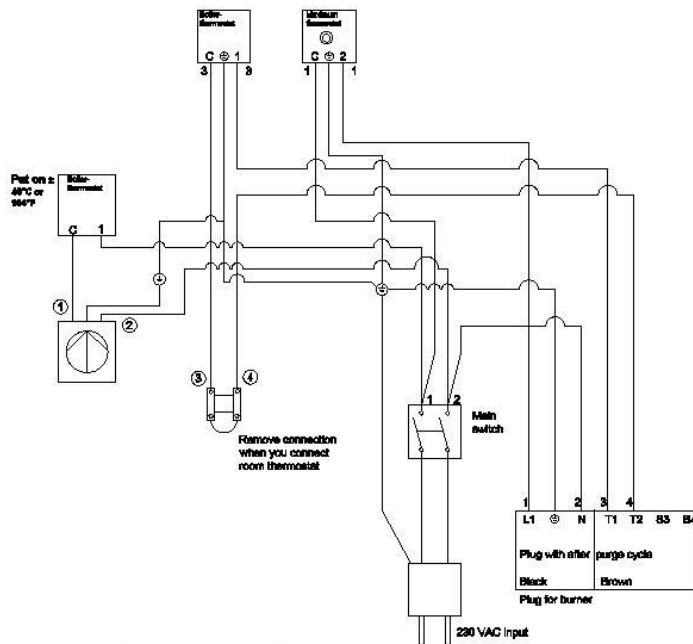

Dimensions wiring
 Power supply 1-1,5 mm²
 thermostat 1-1,5 mm²

Electrical diagram Compact 7, option pump timer

Appendix C Troubleshooting

Listed below you will find a list with possible problems, their reasons and solutions. When you encounter problems not listed, you should contact your dealer. **Never try to solve problems on your own.**

Problem	Possible reason	Possible solution
Burner will not start	Oil supply interrupted	Bleed the oil filter Change contaminated filter element Fill the oil tank
	Power supply interrupted	Check the fuses Check the power supply
Burner stops		Reset burner (once)
	Flame protection dirty (photo cell)	Clean glass of flame protection
	Flame protection defect (photo cell)	Replace flame protection
Burner starts pulsing	Flue gas flow interrupted	Clear chimney opening
	Boiler dirty	Clean boiler
	Oil supply interrupted	See above
	Nozzle defective	Replace nozzle
Burner shows error		Reset burner (once)
	Low voltage	Check voltage level
	Oil supply interrupted	See above
Boiler does not react to thermostat	Wire in main connector has not been removed (room thermostat)	Remove wire from main connector between 1 and 2
	Boiler thermostat incorrectly adjusted	Adjust boiler thermostat
	Battery of room thermostat flat	Replace battery
Water is not circulating	Pump couplings are closed	Open pump couplings
	Pump not connected to electricity supply	Connect pump
	Rotor of pump is stuck	Turn pump with your hand (see pump manual)

The boiler will reset automatically when the problem has disappeared. Action from the user is only required when the NTC-probe is incorrectly installed, the user needs to have the connection of the NTC-probe checked.

Appendix F EG-declaration

EC-declaration of conformity

We,

Kabola Heating Systems BV
Placotiweg 1 E
4131 NL Vianen
The Netherlands

declare under our own responsibility that the product:

Kabola COMPACT 230 V

to which this declaration relates complies with the following standards

EN 303-1, EN 303-2, EN 304, EN 50081-1, EN 50082-1. EN 61010

following the provisions of the following EC-directives

73/23/EEG,
89/336/EEG,
92/42/EEG,
amended by 93/68/EEG.

Nederland, Vianen, 2-9-2010



Kabola Heating Systems B.V.